

KIT N.	KIT 1	KIT 2	KIT 3	KIT 4	KIT 6	KIT 7	KIT 69	KIT 71	KIT 10	KIT 28
Positions Included 包含	4-5-6-7 8-(11)	16	41	9-10	31-34-36 37-38	45	44-47 56	46-47	42-43	42-43 44-45 46-47 56
N. pcs.	6	3	2	6	3	6	3	3	3	1

POS.	CODE	DESCRIPTION	说明	N. PCS.	POS.	CODE	DESCRIPTION	说明	N. PCS.
1	47.1201.41	Testata - OT58 - Brass	铸造黄铜 OT58	1	30	98.2041.00	Tappo G 1/4x9	螺塞	1
2	99.3206.00	Vite M8x70 UNI 5737	螺栓	8	31	90.3585.00	OR Ø 10,82x1,78	o型圈子	KIT 6 4
3	96.7020.00	Rosetta Ø 8 UNI 1736	垫圈	8	32	99.3099.00	Vite M8x35 UNI 5931	螺栓	6
4	90.3841.00	OR Ø 17,13x2,62	o型圈	KIT 1 6	33	96.7014.00	Rosetta Ø 8,4x13x0,8	垫圈	6
5	36.2003.66	Sede valvola	阀座	KIT 1 6	34	96.7286.00	Rosetta Ø 14x28x0,5	垫圈	KIT 6 3
6	36.2001.76	Valvola	阀	KIT 1 6	35	47.0404.09	Pistone Ø 20	柱塞	3
7	94.7376.00	Molla Ø 9,4x14,8	弹簧	KIT 1 6	36	90.5067.00	Anello per OR	密封圈	KIT 6 3
8	36.2002.51	Guida valvola	阀导向	KIT 1 6	37	96.7280.00	Rosetta Ø 14x18,5x0,5	垫圈	KIT 6 3
9	90.3847.00	OR Ø 20,24x2,62	o型圈	KIT 4 6	38	47.2195.66	Vite fissaggio pistone	柱塞螺丝	KIT 6 3
10	98.2220.00	Tappo M 24x2x16	螺丝	KIT 4 6	39	47.1500.22	Coperchio carter	曲轴箱盖	1
11	36.7032.01	Gruppo valvola	阀单元	KIT 1 6	40	97.5678.00	Spessore	薄片	2
12	99.3039.00	Vite M8x16 UNI 5931	螺栓	8	41	90.1648.00	Anello radiale Ø 30x55x7	油封	KIT 3 1
13	47.1501.22	Coperchio carter	曲轴箱盖	1	42	90.3616.00	OR Ø 34,65x1,78	o型圈	KIT 10-28 3
14	90.3913.00	OR Ø 67,95x2,62	o型圈	2	43	47.0805.70	Anello di fondo Ø 20	密封圈	KIT 10-28 3
15	91.8375.00	Cuscinetto a rulli 32206	滚子轴承	2	44	90.2705.00	Anello tenuta Ø 20 H.P. seal	高压密封圈	KIT 28-69 3
16	90.1625.00	Anello radiale Ø 22x32x5,5	油封	KIT 2 3	45	47.1000.51	Anello testa Ø 20	第一环	KIT 7-28 3
17	90.9126.00	Boccola Ø 22x25x30	衬套	3	46	47.2169.70	Anello intermedio Ø 20	中间环	KIT 28-71 3
18	47.0100.22	Carter	曲轴箱	1	47	90.2704.00	Anello "RESTOP" Ø 20	限位环	KIT 28-69-71 3
19	98.2106.00	Tappo carico olio G 3/8	油标螺丝	1	48	47.2000.74	Piedino	底脚	2
20	90.3922.00	OR Ø 133,02x2,62	o型圈	1	49	99.3644.00	Vite M10x18 UNI 5931	螺栓	4
21	47.0204.35	Albero semplice P. di F. WS102	曲轴	1	50	96.7106.00	Rosetta Ø 10 DIN 7980	垫片	4
	47.0210.35	Albero semplice P. di F. WS131		1	51	98.2176.00	Tappo G 1/2x10	螺丝	1
	47.0206.35	Albero semplice P. di F. WS151		1	52	96.7514.00	Rosetta Ø 21,5x27x1,5	垫片	1
	47.0215.35	Albero semplice P. di F. WS171		1	53	98.2100.00	Tappo G 3/8x13	螺丝	1
22	90.0557.00	Anello di fermo	轴用挡圈	6	54	96.7380.00	Rosetta Ø 17,5x23x1,5	垫片	1
23	91.4878.00	Linguetta	键	1	56	90.2710.00	Anello tenuta Ø 20 L.P. seal	低压密封环	KIT 28-69 3
24	97.7380.00	Spinotto Ø 13x35	销子	3					
25	47.0505.54	Guida pistone	柱塞导向	3					
26	47.0300.01	Biella completa	连杆	3					
27	99.1912.00	Vite M6x30 UNI 5931	螺栓	5					
28	47.1601.22	Coperchio carter	曲轴箱盖	1					
29	97.5968.00	Spia olio G 3/4	油标螺丝	1					

OVERALL DIMENSIONS

外型尺寸

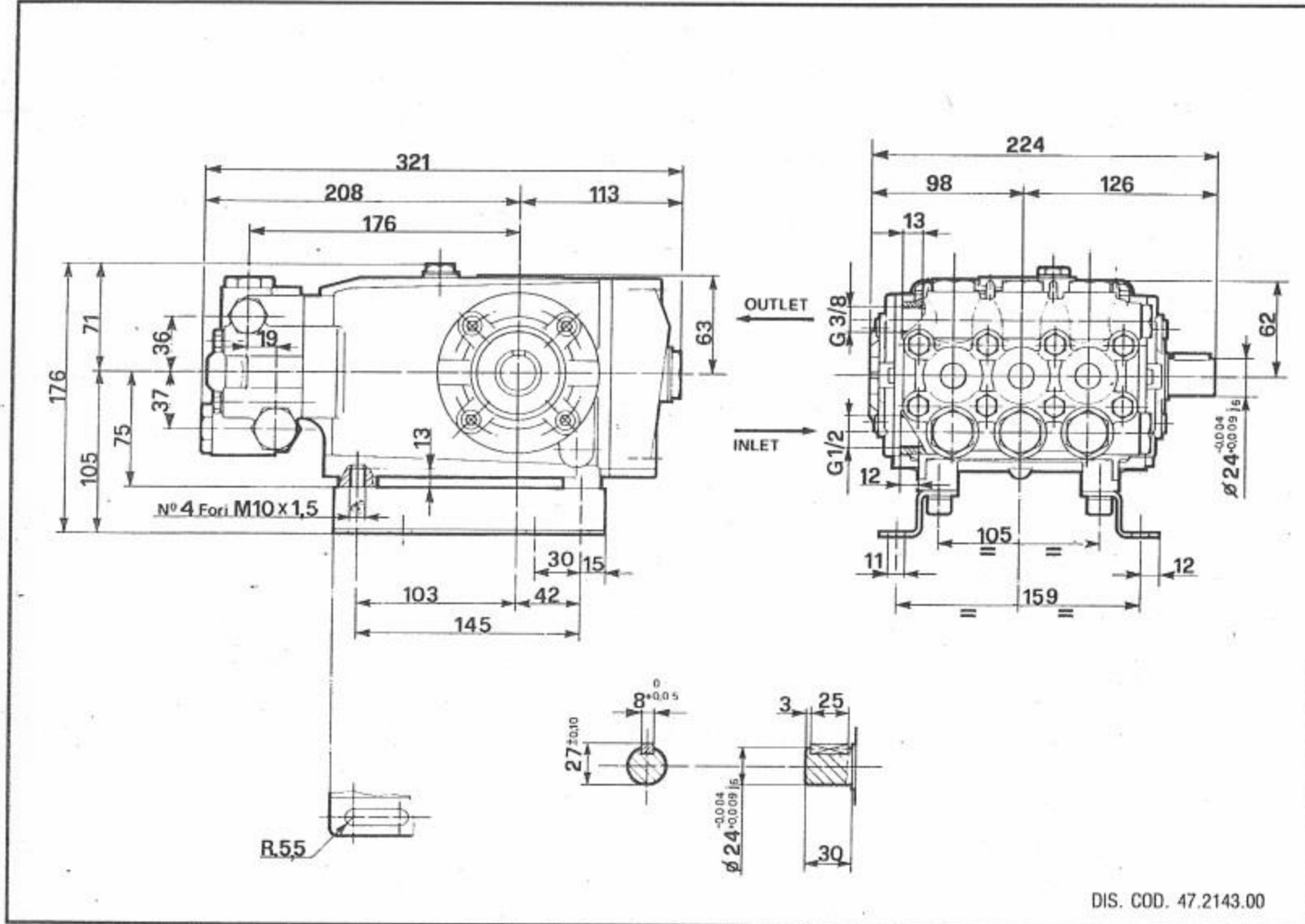

Revisione n. 3



INTERPUMP GROUP



PUMP

WS102 - WS131
WS151 - WS171

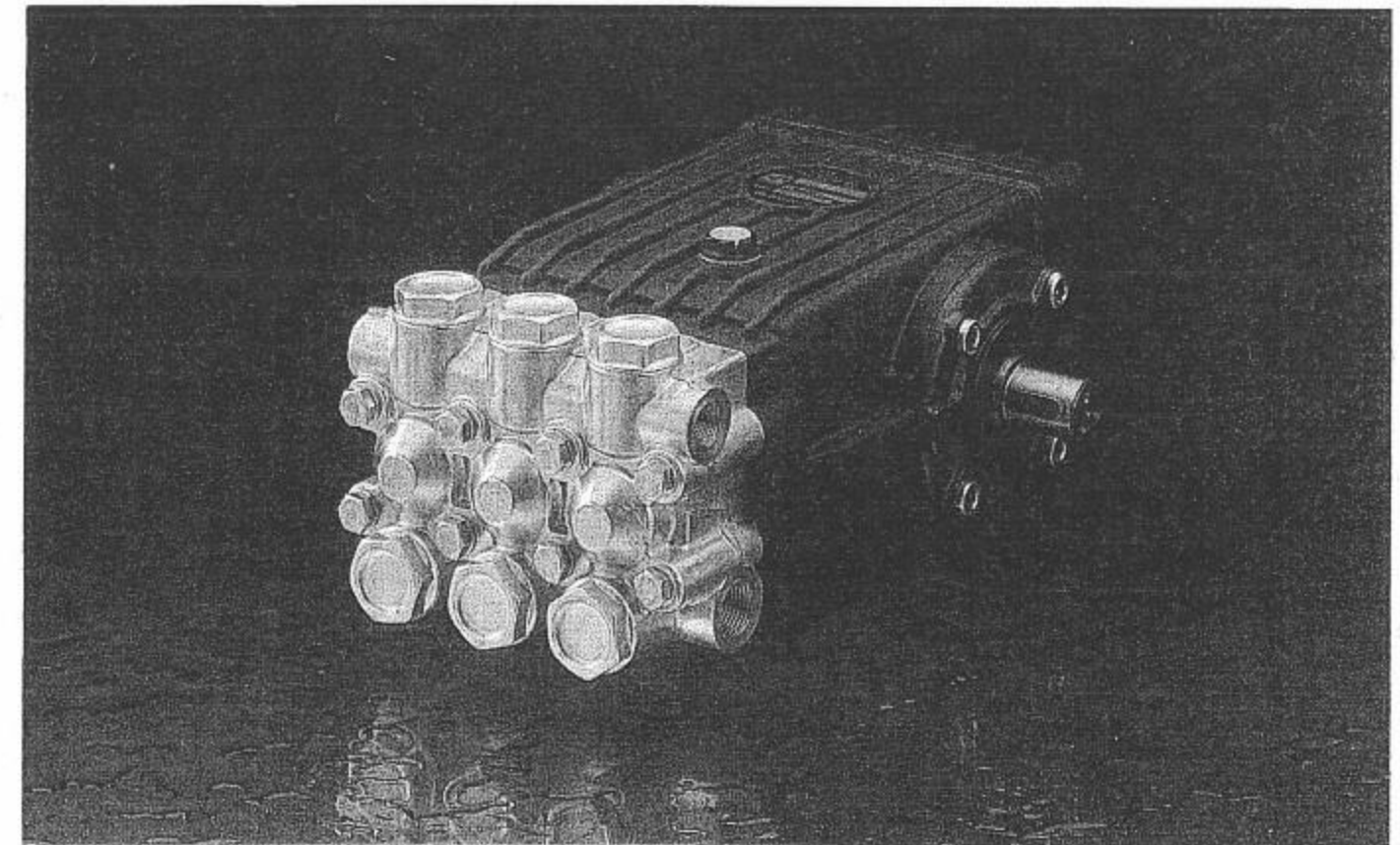

LUBRICATION: We recommend INTERPUMP OIL X-9.9. (SAE 15W40 Mineral) - OIL CAPACITY / 1.2

润滑：我们建议您使用INTERPUMP OIL X-9.9 (SAE 15W40 Mineral) 加油量1.2L

Cod. 47.2240.03 - 02/07 - 5.000 De Pietri

pump type 泵型号	volume 流量		pressure 压力		r.p.m. 转速	required 输入功率		weight kg. 重量	overall dimensions 外型尺寸
	l/min	G.P.M. (USA)	bar	p.s.i.		hp	kw		
WS102	21	5.55	100	1450	1450	5,5	4,04	14,5	321x224x176
WS131	15	3.96	130	1885	1450	5,5	4,04	14,5	321x224x176
WS151	15	3.96	150	2175	1450	5,5	4,04	14,5	321x224x176
WS171	13	3.43	170	2465	1450	5,5	4,04	14,5	321x224x176

