

**INTERPUMP
GROUP**
INTERNATIONAL TECHNICAL COMPANY

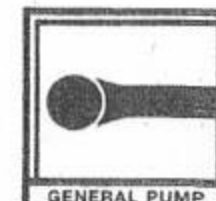

PUMP

TH 2000 - TH 2500 - TH 3000 - TH 3500

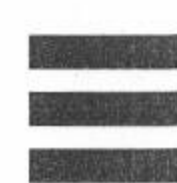
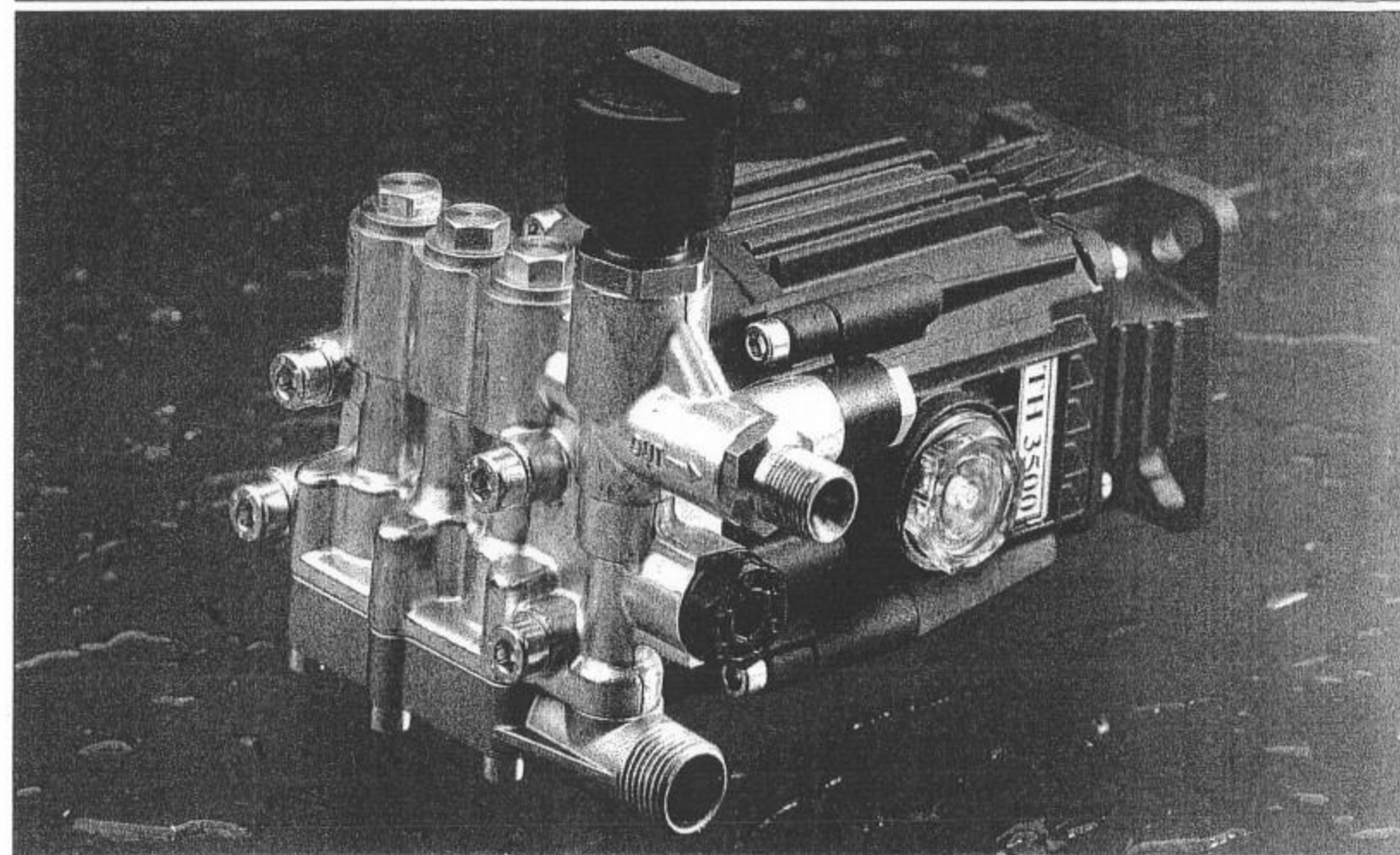

pump type 泵型号	volume 流量		pressure 压力		r.p.m. 转速	required 输入功率 HP/kW	weight kg. 重量	overall dimensions 外型尺寸
	G.P.M.(USA)	l/min.	p.s.i.	bar				

ALL./NICKEL MANIFOLD VERSION

TH 2000	2	7,6	1600	110	3600	2,2/1,61	3,8	mm 227x172x181 inches 8.94x6.77x7.12
TH 2500	2.5	9,5	1600	110	3600	2,8/2,05	3,8	
TH 3000	3	11,3	1600	110	3600	3,3/2,42	3,8	
TH 3500	3.5	13,2	1600	110	3600	3,8/2,79	3,8	

BRASS MANIFOLD VERSION

TH 2000	2	7,6	2030	140	3600	2,8/2,05	5,2	mm 227x172x181 inches 8.94x6.77x7.12
TH 2500	2.5	9,5	2030	140	3600	3,5/2,57	5,2	
TH 3000	3	11,3	2030	140	3600	4,1/3,00	5,2	
TH 3500	3.5	13,2	2030	140	3600	4,8/3,52	5,2	



INTERPUMP GROUP

VIA E. FERMI, 25 - 42040 S. ILARIO - REGGIO EMILIA (ITALY)
TEL. +39 - 0522 - 904311 - TELEFAX + 39 - 0522 - 904444
E-mail: info@interpumpgroup.it - http://www.interpumpgroup.it

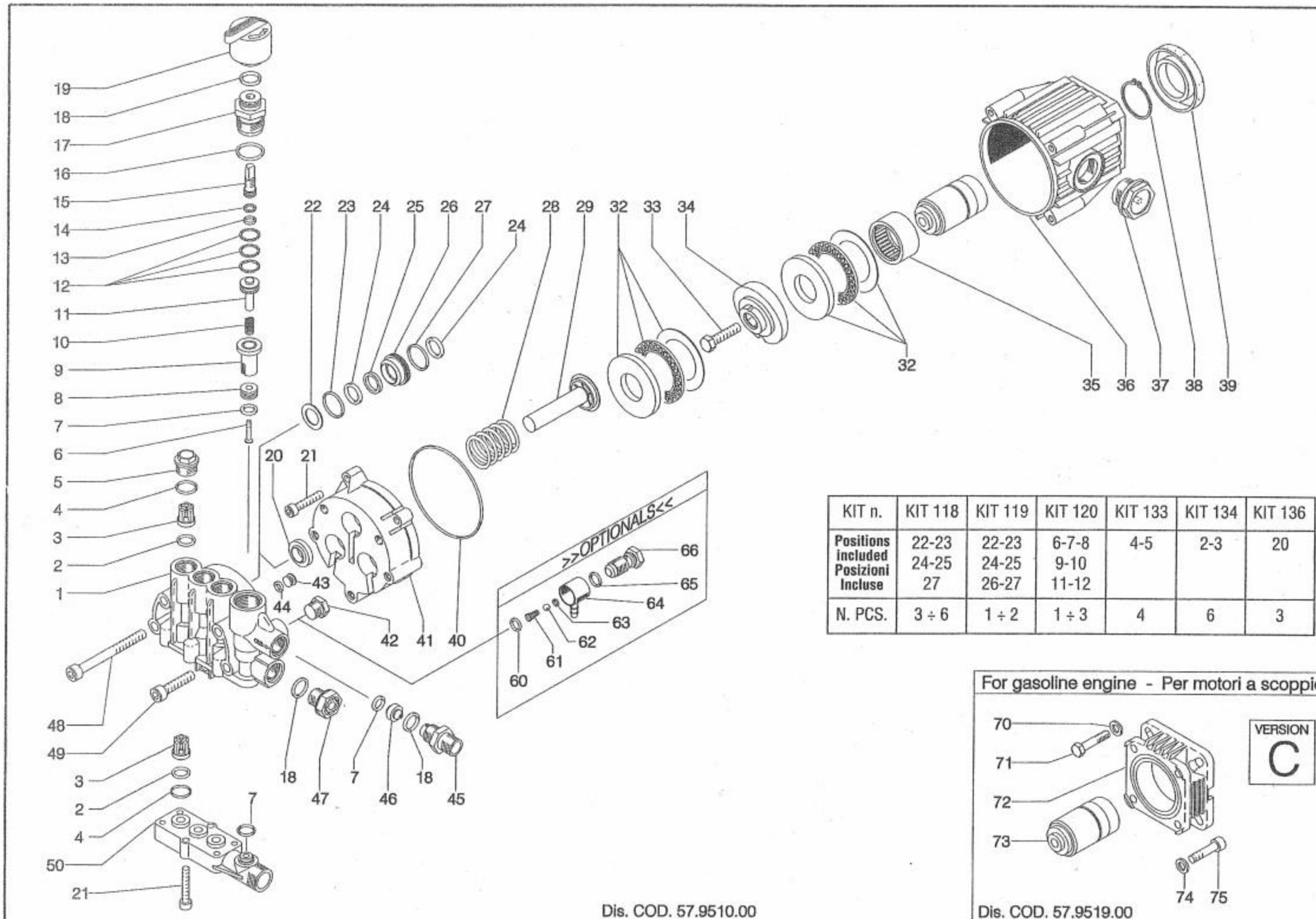

Dis. COD. 57.9510.00

Dis. COD. 57.9519.00

POS.	CODE	DESCRIPTION	N. PCS.
1	57120122	Testata All./Nickel	1
2	90358900	OR Ø 12,42x1,78	6
3	36711601	Gruppo Valvola	6
4	90359300	OR Ø 15,60x1,78	6
5	98213500	Tappo M 18x1,5x10	3
6	36319666	Valvola	1
7	90382300	OR Ø 9,92x2,62	3
8	36319766	Sede Valvola	1
9	36319551	Distanziale	1
10	94822000	Molla Conica Ø 5,15/8,35x12	1
11	36319470	Pistoncino di Comando	1
12	92770500	Fascia Elastica Ø 17	3
13	90357800	OR Ø 7,66x1,78	1
14	90503300	Anello per OR	1
15	36319270	Vite di Regolazione	1
16	90384700	OR Ø 20,24x2,62	1
17	36319370	Boccola di Guida	1
18	90383300	OR Ø 13,95x2,62	3
19	36319151	Pomolo	1
20	90156700	Anello Radiale Ø 15x25,4x7	3
21	99191400	Vite autof. M 6x30	10
22	96736000	Rosetta Ø 16,5x24,8x1	3
23	90360000	OR Ø 21,95x1,78	3
24	90383500	OR Ø 15,08x2,62	6
25	90508900	Anello per OR	3
26	51080270	Anello di Fondo Ø 15	3
27	90360400	OR Ø 25,12x1,78	3
28	94766400	Molla Ø 33,5x56	3

POS.	CODE	DESCRIPTION	N. PCS.
29	54040101	Assieme pistone Ø 15	3
32	91834700	Cuscinetto assiale a rulli	2
33	99306800	Vite M 8x25 UNI 5739	1
34	57210722	Piatto inclinato TH 3500	1
	57211122	Piatto inclinato TH 3000	1
	57211222	Piatto inclinato TH 2500	1
	57211322	Piatto inclinato TH 2000	1
35	91845500	Boccola a rullini	1
36	57010622	Carter	1
37	97596800	Spia livello olio G 3/4	1
38	90069500	Anello di fermo Ø 35 UNI 7435	1
39	90167400	Anello radiale Ø 35x62x10	1
40	90391700	OR Ø 88,57x2,62	1
41	57210422	Corpo guida pistoni	1
42	98205700	Tappo M 14x1,5x9	1
43	57210070	Tappo Ø 10	1
44	90381400	OR Ø 5,23x2,62	1
45	10007870	Nipplo G 3/8 con Ø 3	1
	10014770	Nipplo M 22x1,5 con Ø 3 (No standard)	1
	10030766	Ugello Ø 1,8 (TH 2000)	1
46	10015166	Ugello Ø 2 (TH 2500 - TH 3000)	1
	10007666	Ugello Ø 2,2 (TH 3500)	1
47	98209000	Tappo G 3/8x13	1
48	99321000	Vite M 8x70 UNI 5931	4
49	99306900	Vite M 8x25 UNI 5931	1
50	57140022	Collettore aspirazione All./Nickel	1

POS.	CODE	DESCRIPTION	N. PCS.
60	90358200	OR Ø 9,25x1,78	1
61	94821700	Molla Conica Ø 4,3/7,3x11	1
62	97478200	Sfera 7/32	1
63	90357200	OR Ø 5,28x1,78 - spec.	1
64	36260451	Corpo aspirazione detergente	1
65	90358500	OR Ø 10,82x1,78	1
66	36256370	Sede valvola	1

C FOR GASOLINE ENGINES

POS.	CODE	DESCRIPTION	N. PCS.
70	96701400	Rosetta Ø 8,4 Schnorr	4
71	99273000	Vite 5/16"x3/4"x24 UNF	4
72	10034622	Flangia per motore a scoppio	1
73	57020165	Albero cavo - Ø 3/4"	1
74	96693800	Rosetta Ø 6,4 Schnorr	4
75	99186700	Vite M 6x18 UNI 5931	4

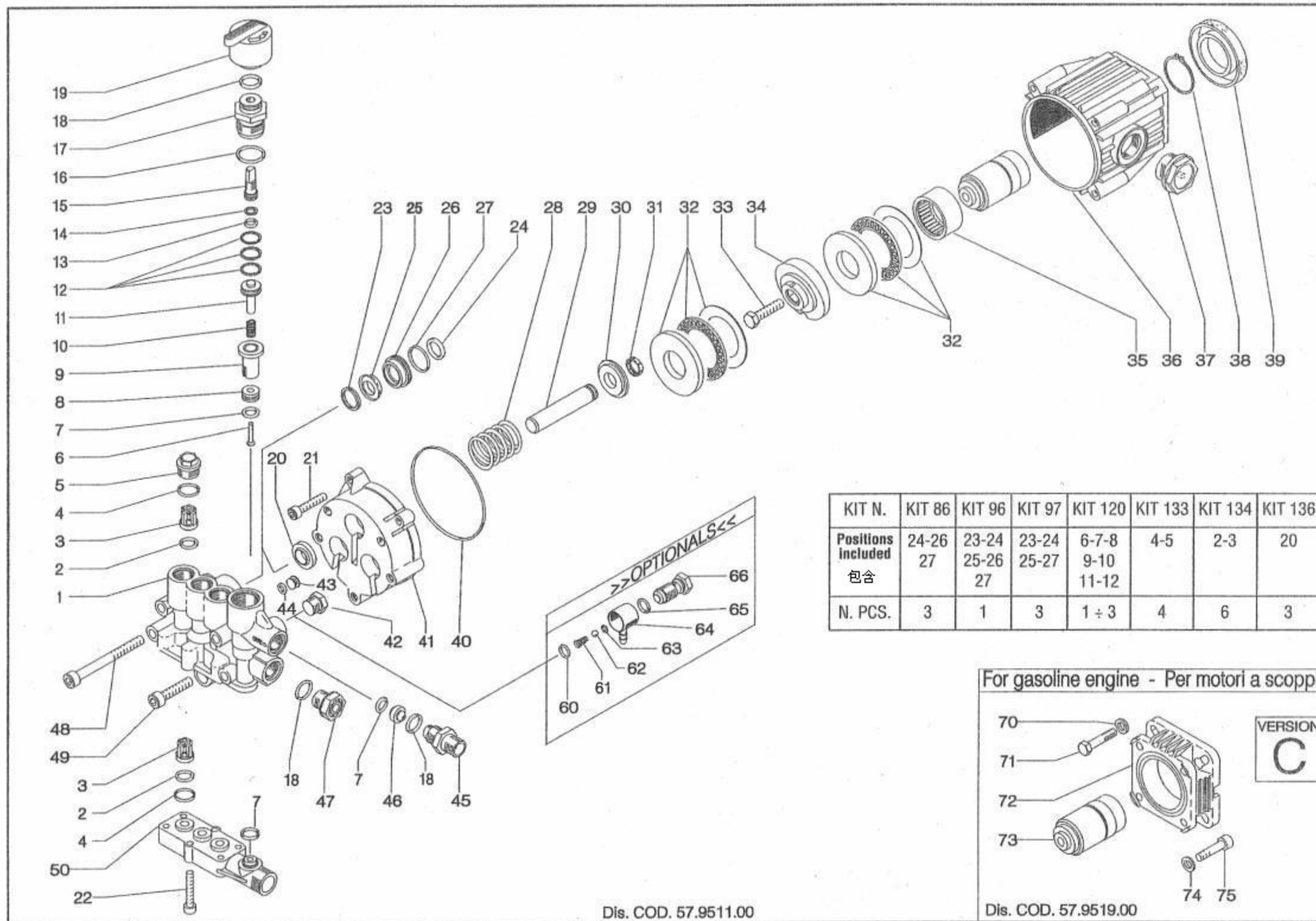

KIT N.	KIT 86	KIT 96	KIT 97	KIT 120	KIT 133	KIT 134	KIT 136
Positions included	24-26 27	23-24 25-26 27	23-24 25-27	6-7-8 9-10 11-12	4-5	2-3	20
N. PCS.	3	1	3	1 ÷ 3	4	6	3

For gasoline engine - Per motori a scoppio

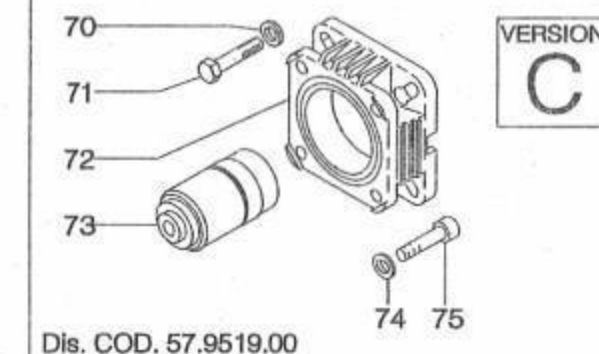

POS.	CODE CODICE	DESCRIPTION - DESCRIZIONE	N. PCS.
1	57120241	Testata	1
2	90358900	OR Ø 12,42x1,78	6
3	36711601	Gruppo Valvola	6
4	90359300	OR Ø 15,60x1,78	6
5	98213500	Tappo M 18x1,5x10	3
6	36319666	Valvola	3
7	90382300	OR Ø 9,92x2,62	3
8	36319766	Sede Valvola	1
9	36319551	Distanziale	1
10	94822000	Molla Conica Ø 5,15/8,35x12	1
11	36319470	Pistoncino di Comando	1
12	92770500	Fascia Elastica Ø 17	3
13	90357800	OR Ø 7,66x1,78	1
14	90303300	Anello per OR	1
15	36319270	Vite di Regolazione	1
16	90384700	OR Ø 20,24x2,62	1
17	36319370	Boccola di Guida	1
18	90383300	OR Ø 13,95x2,62	3
19	36319151	Pomolo	1
20	90156700	Anello Radiale Ø 15x25,4x7	3
21	99191400	Vite autof. M 6x30	4
22	99191200	Vite M 6x30 UNI 5931	6
23	51100051	Anello di testa Ø 15	3
24	90383500	OR Ø 15,08x2,62	3
25	90262000	Anello di tenuta Ø 15	3
26	51080070	Anello di Fondo Ø 15	3
27	90360400	OR Ø 25,12x1,78	3
28	94766400	Molla Ø 33,5x56	3
29	57040102	Assieme pistone Ø 15	3

POS.	CODE CODICE	DESCRIPTION - DESCRIZIONE	N. PCS.
30	57210370	Piattello molla	3
31	57208551	Anello di fermo	2
32	91834700	Cuscinetto assiale a rulli	1
33	99306800	Vite M 8x25 UNI 5739	1
34	57210722	Piatto inclinato TH 3500	1
	57211122	Piatto inclinato TH 3000	1
	57211222	Piatto inclinato TH 2500	1
	57211322	Piatto inclinato TH 2000	1
35	91845500	Boccola a rullini	1
36	57010622	Carter	1
37	97596800	Spia livello olio G 3/4	1
38	90069500	Anello di fermo Ø 35 UNI 7435	1
39	90167400	Anello radiale Ø 35x62x10	1
40	90391700	OR Ø 88,57x2,62	1
41	57210422	Corpo guida pistoni	1
42	98205700	Tappo M 14x1,5x9	1
43	57210070	Tappo Ø 10	1
44	90381400	OR Ø 5,23x2,62	1
45	10007870	Nipplo G 3/8 con Ø 3	1
	10014770	Nipplo M 22x1,5 con Ø 3 (No standard)	1
	10043770	Ugello Ø 1,6 (TH 2000)	1
46	10030766	Ugello Ø 1,8 (TH 2500)	1
	10015166	Ugello Ø 2 (TH 3000)	1
	10007666	Ugello Ø 2,2 (TH 3500)	1
47	98209000	Tappo G 3/8x13	1
48	99321000	Vite M 8x70 UNI 5931	4
49	99306900	Vite M 8x25 UNI 5931	1
50	57140022	Collettore aspirazione All./Nickel	1

POS.	CODE CODICE	DESCRIPTION - DESCRIZIONE	N. PCS.
>> OPTIONALS <<			
60	90358200	OR Ø 9,25x1,78	1
61	94821700	Molla Conica Ø 4,3/7,3x11	1
62	97478200	Sfera 7/32	1
63	90357200	OR Ø 5,28x1,78 - spec.	1
64	36260451	Corpo aspirazione detergente	1
65	90358500	OR Ø 10,82x1,78	1
66	36256370	Sede valvola	1

C FOR GASOLINE ENGINES - PER MOTORI A SCOPPIO			
70	96701400	Rosetta Ø 8,4 Schnorr	4
71	99273000	Vite 5/16"x3/4"x24 UNF	4
72	10034622	Flangia per motore a scoppio	1
73	57020165	Albero cavo - Ø 3/4"	1
74	96693800	Rosetta Ø 6,4 Schnorr	4
75	99186700	Vite M 6x18 UNI 5931	4

